

ME 111: Engineering Drawing

Lecture # 13 (26/09/2011)

Intersections of Solids 2

Indian Institute of Technology Guwahati
Guwahati – 781039

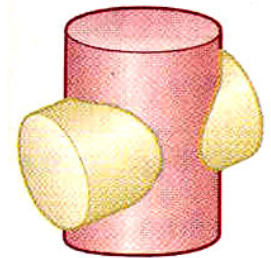

Questions for Practice

INTERSECTION OF PRISM AND PRISM (with axis perpendicular and offset)

Prob. 1) A vertical square prism, base 50 mm side, is completely penetrated by a horizontal square prism, base 35 mm side, so that their axis are 6 mm apart. The axis of the horizontal prism is parallel to the VP, while the faces of both prisms are equally inclined to the VP. Draw the projections of the prisms showing lines of intersection. (Assume that the length of both the prisms is 100 mm).

(Book: *N. D. Bhatt*)

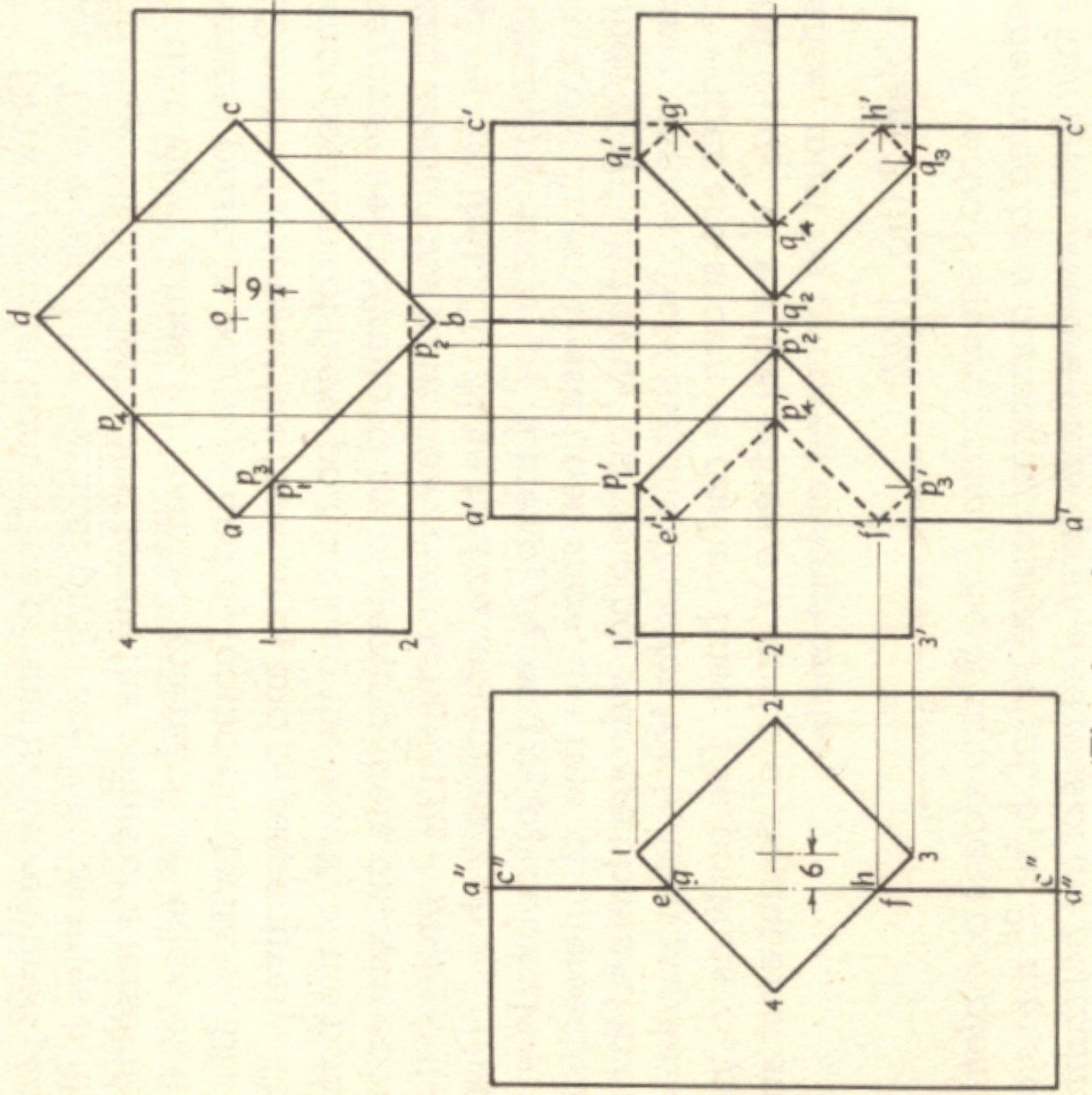

(Third-angle projection)

INTERSECTION OF PRISM AND PRISM

Prob. 2) A vertical square prism, base 50 mm side and height 90 mm has a face inclined at 30° to the VP. It is completely penetrated by another horizontal square prism, base 40 mm side and axis 100 mm long, faces of which are equally inclined to the VP. The axis of the two prisms are parallel to the VP and bisect each other at right angles. Draw the projections showing lines of intersection.

(Book: *N. D. Bhatt*)

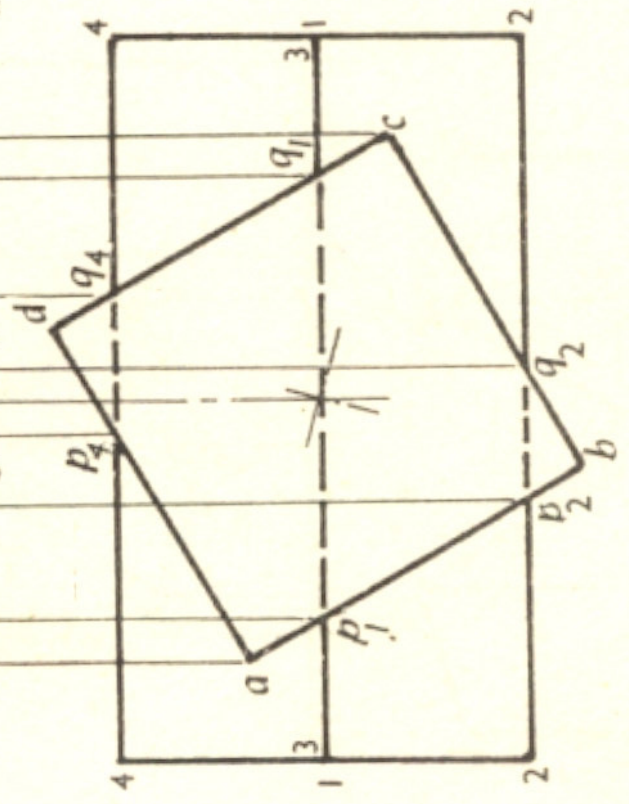
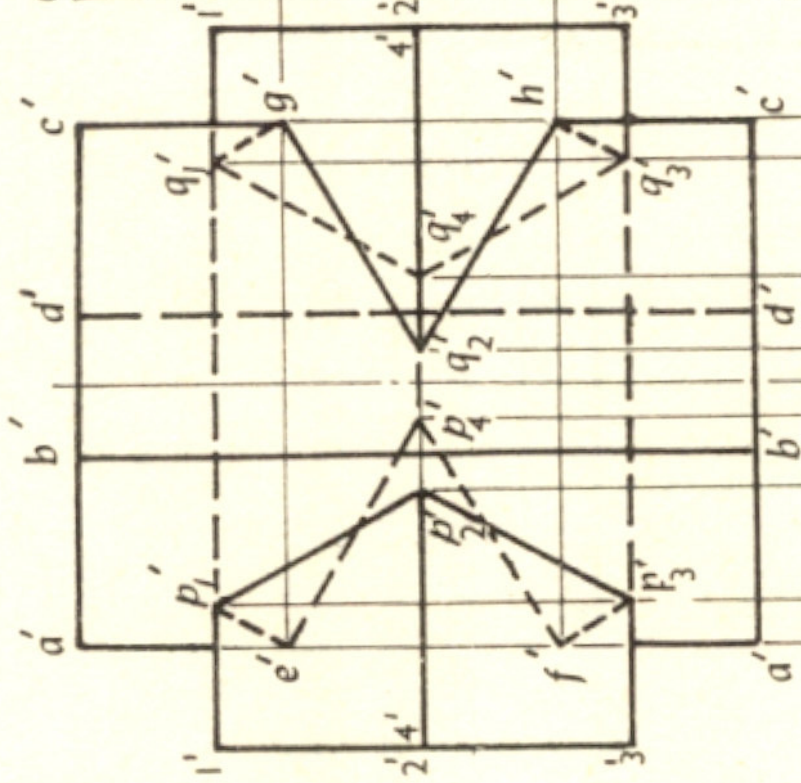
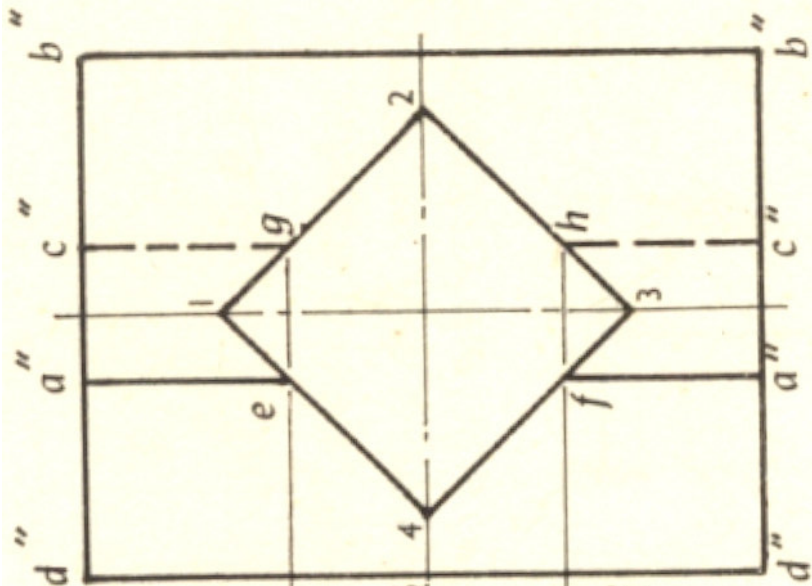

Prob. 3) A square prism of 40 mm edge of base and 90 mm high rests vertically with its base on HP such that the front right vertical rectangular face is inclined at 60° to VP. This prism is penetrated by another horizontal square prism whose rectangular faces make equal inclination with both HP and VP. The axis of the horizontal prism is passing at the mid height at a distance of 10 mm in front of the vertical prism. The horizontal square prism is of the same dimensions as that of the vertical square prism. Draw the lines of intersection

(Taken from K.R. Gopslakrishna, Engg. Drawing, subhas store book center)

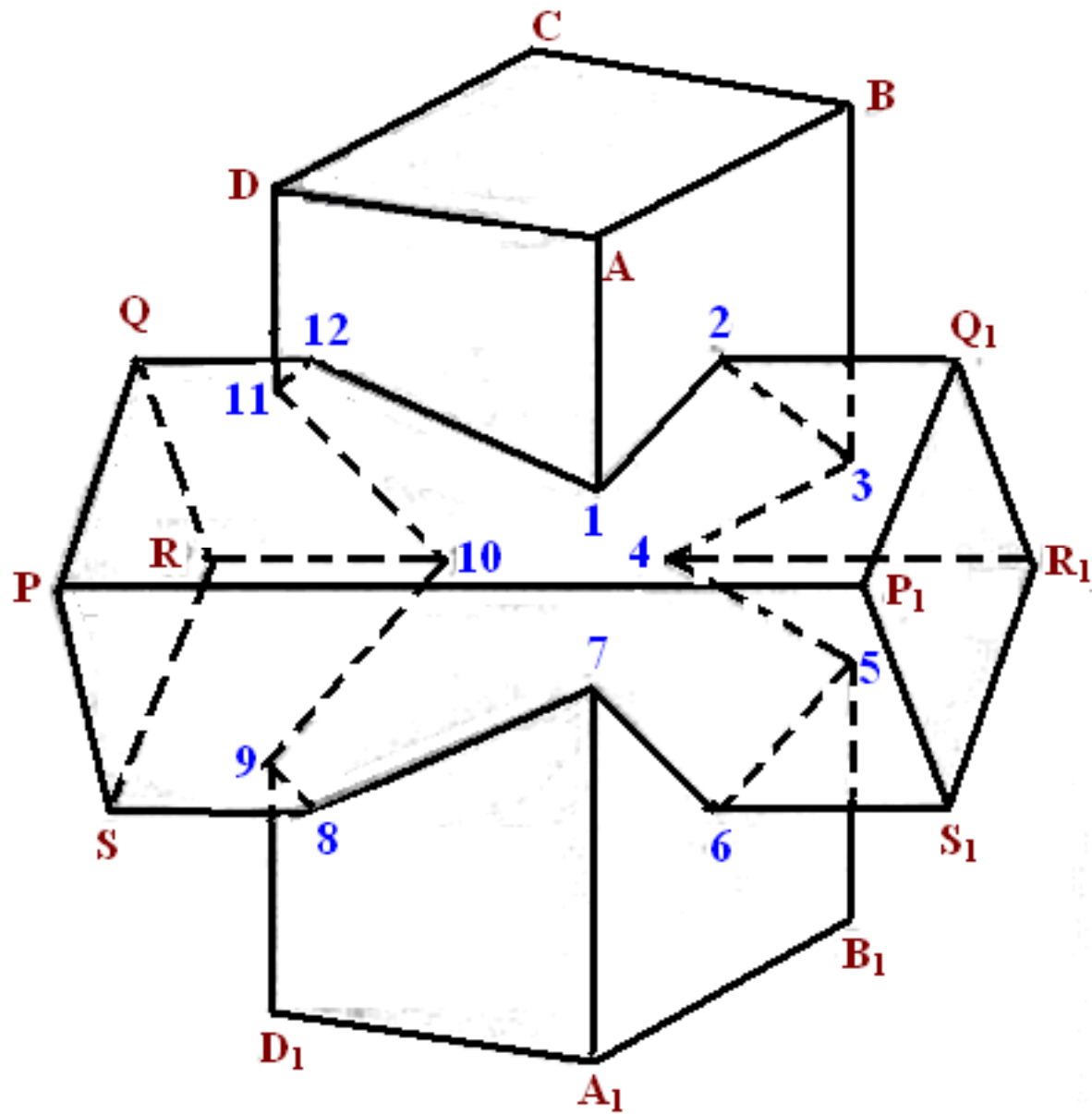

(Taken from K.R. Gopslakrishna, Engg. Drawing, subhas store book center)

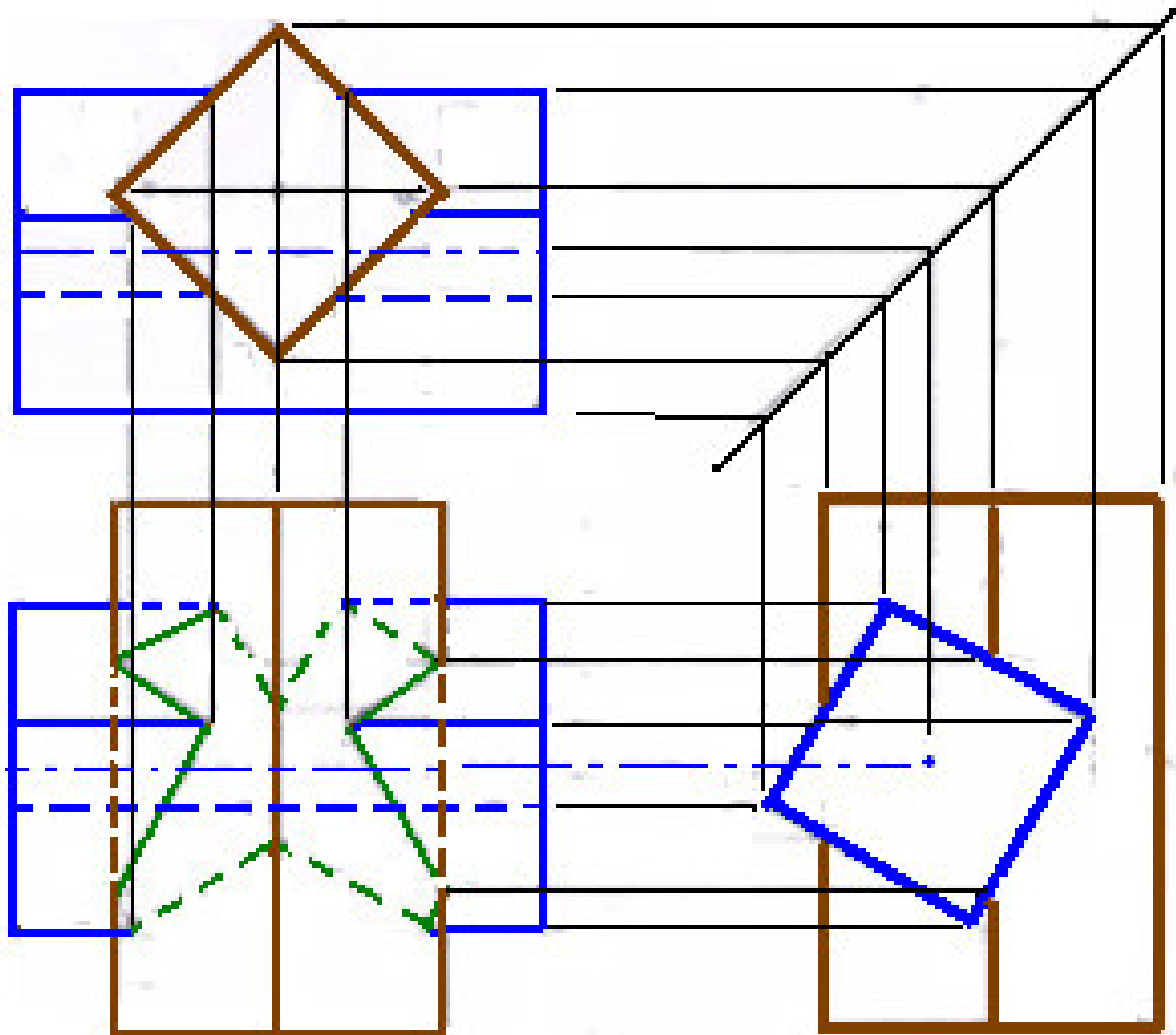
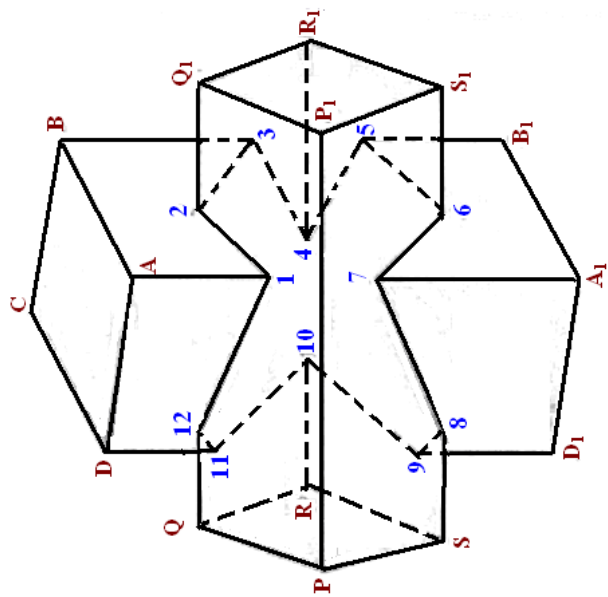

INTERSECTION OF CYLINDER AND CONE (with axis perpendicular and offset)

Prob. 4) A cone with a base diameter of 64 mm and an axis length of 70 mm is kept on its base on the HP. A cylinder of diameter 30 mm and length 90 mm penetrates the cone horizontally. The axis of the cylinder is 20 mm above the base of the cone and 5 mm away from the axis of the latter. Draw the three views of the solids showing curve of intersection.

(Taken from Dhananjay A Jolhe, Engg. Drawing, MGH)

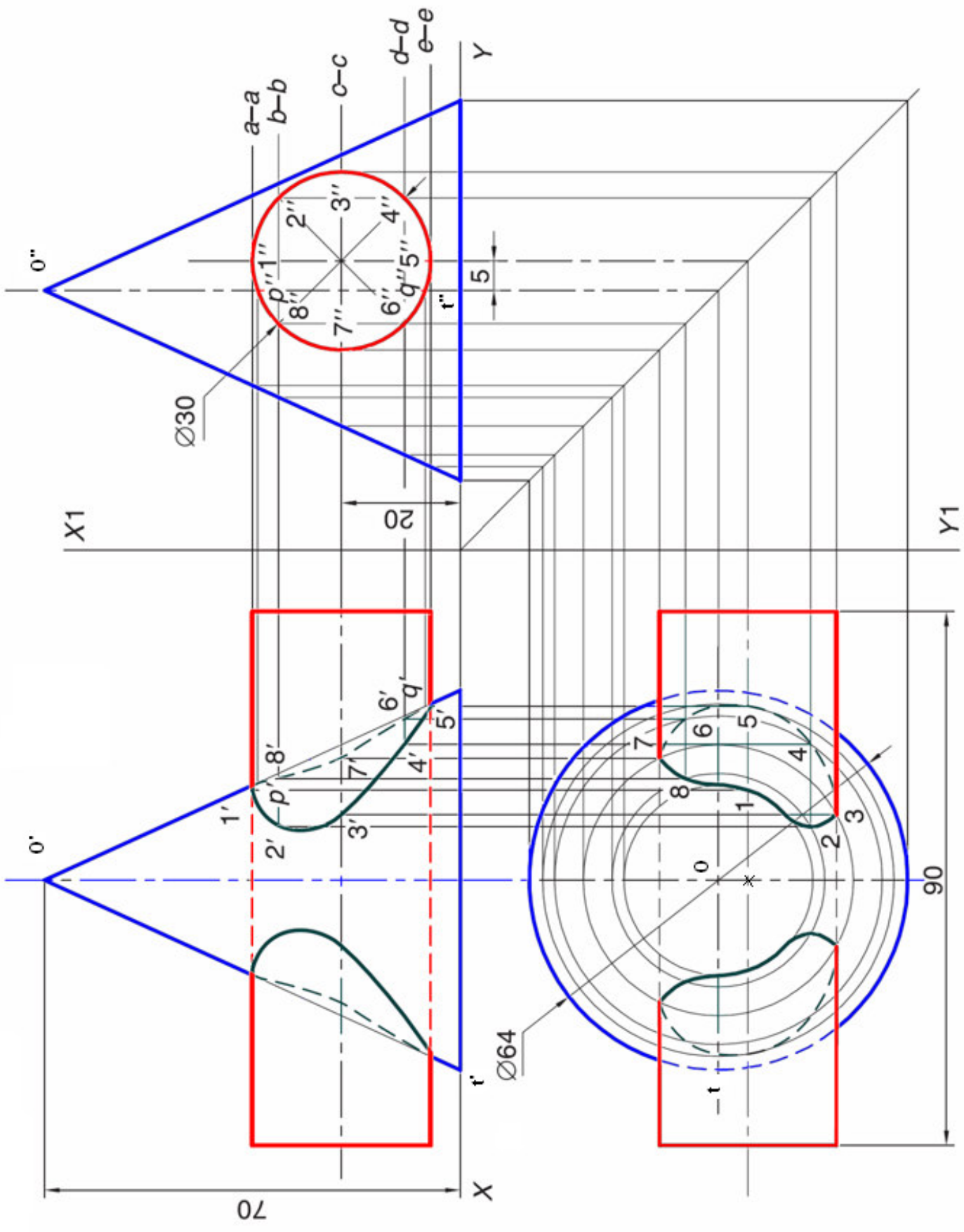

INTERSECTION OF PRISM AND CYLINDER (with axis perpendicular and offset)

Prob. 5) A vertical cylinder with a 60 mm diameter is penetrated by a horizontal square prism with a 40 mm base side, the axis of which is parallel to the VP and 10 mm away from the axis of the cylinder. A face of the prism makes an angle of 30° with the HP. Draw their projections showing curves of intersection.

(Taken from Dhananjay A Jolhe, Engg. Drawing, MGH)

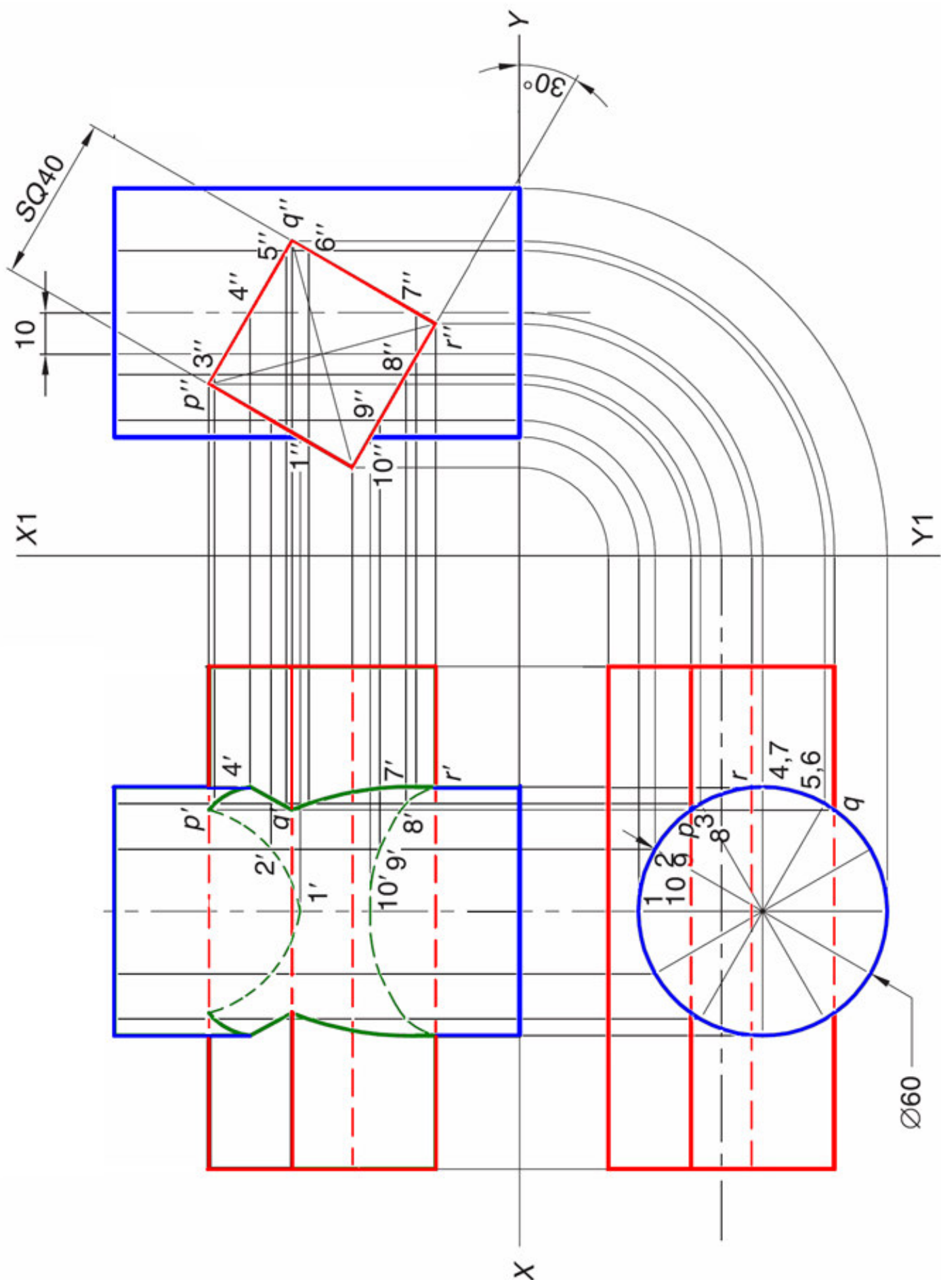

Prob. 6)

A vertical pentagonal prism 30 mm edge of base and height 100 mm has one of its rectangular faces parallel to VP and nearer to it. It is penetrated by a rectangular prism of side 40mm x 20 mm and 100 mm high, with its front largest lower front rectangular face inclined at 60° to HP. The axis of the rectangular prism is inclined at 30 ° to HP and parallel to VP, 5 mm in front of the axis of the pentagonal prism and appears to bisect it in the front view. Draw the interpenetration line.

(Taken from K.R. Gopslakrishna, Engg. Drawing, subhas store book center)

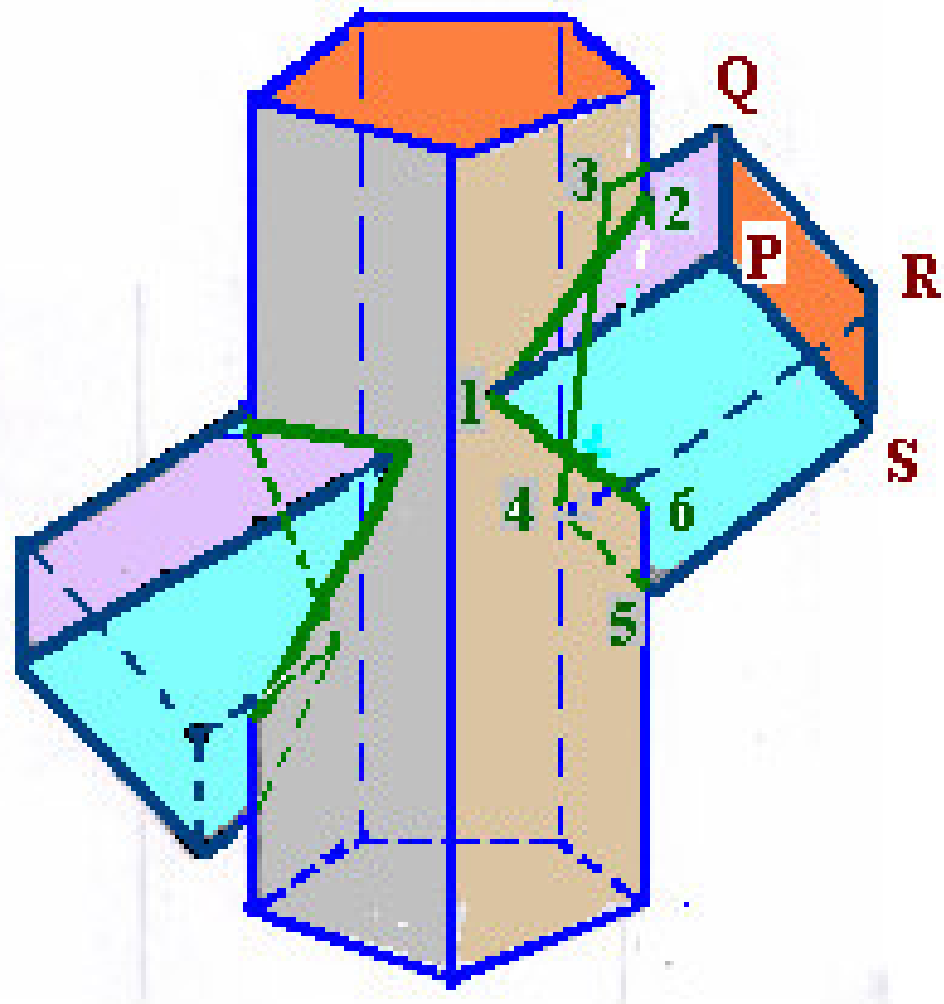

(Taken from K.R. Gopslakrishna, Engg. Drawing, subhas store book center)

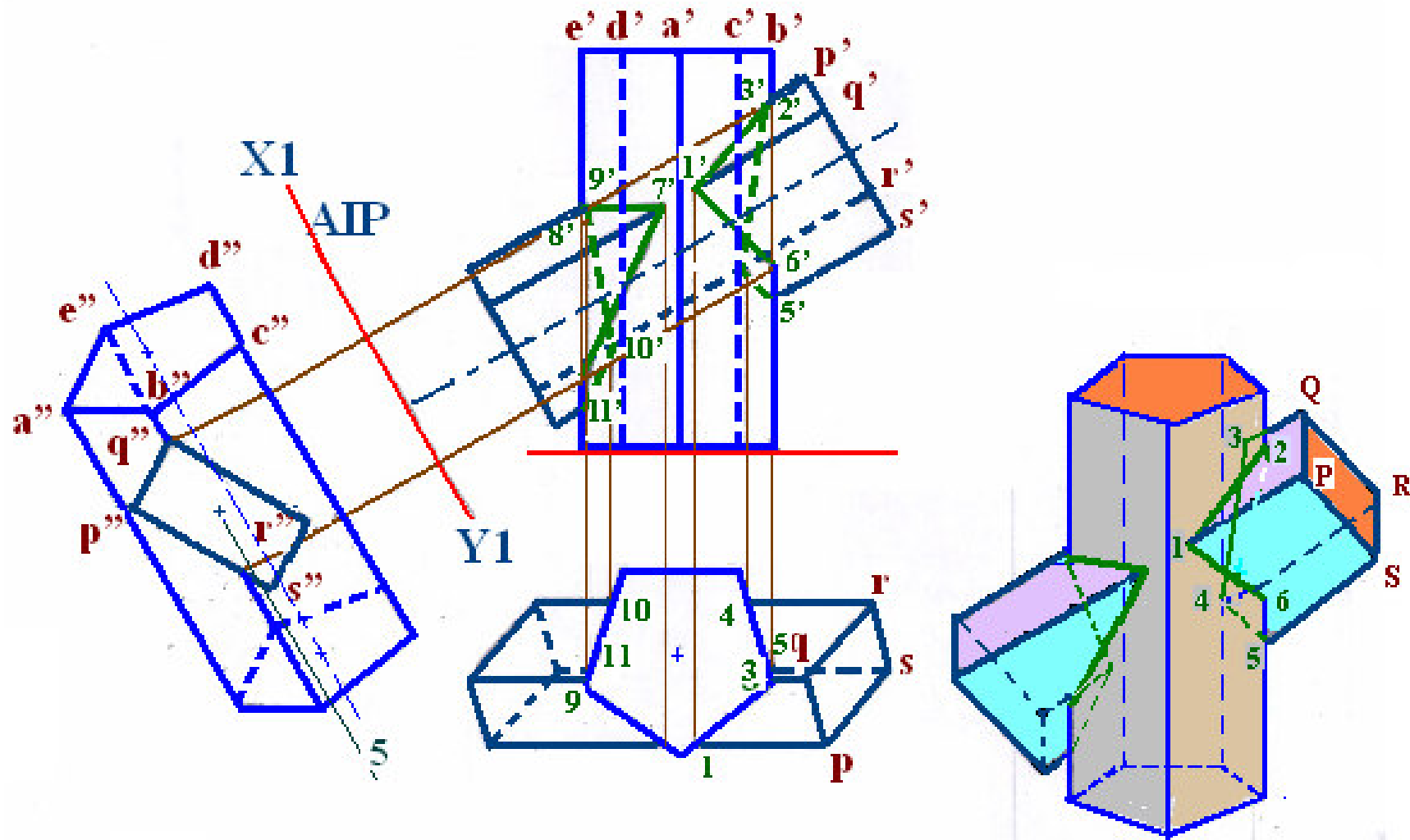

(Taken from K.R. Gopslakrishna, Engg. Drawing, subhas store book center)

Prob. 7) A vertical cylinder of 40 mm diameter and 80 mm high is intersected by another cylinder of 35 mm diameter and 80 mm long. The axis of the penetrating cylinder is inclined at 30° to HP, parallel to VP, 6 mm in front of the vertical cylinder and appears to bisect it in front view. Draw the intersection curve.

(Taken from K.R. Gopslakrishna, Engg. Drawing, subhas store book center)

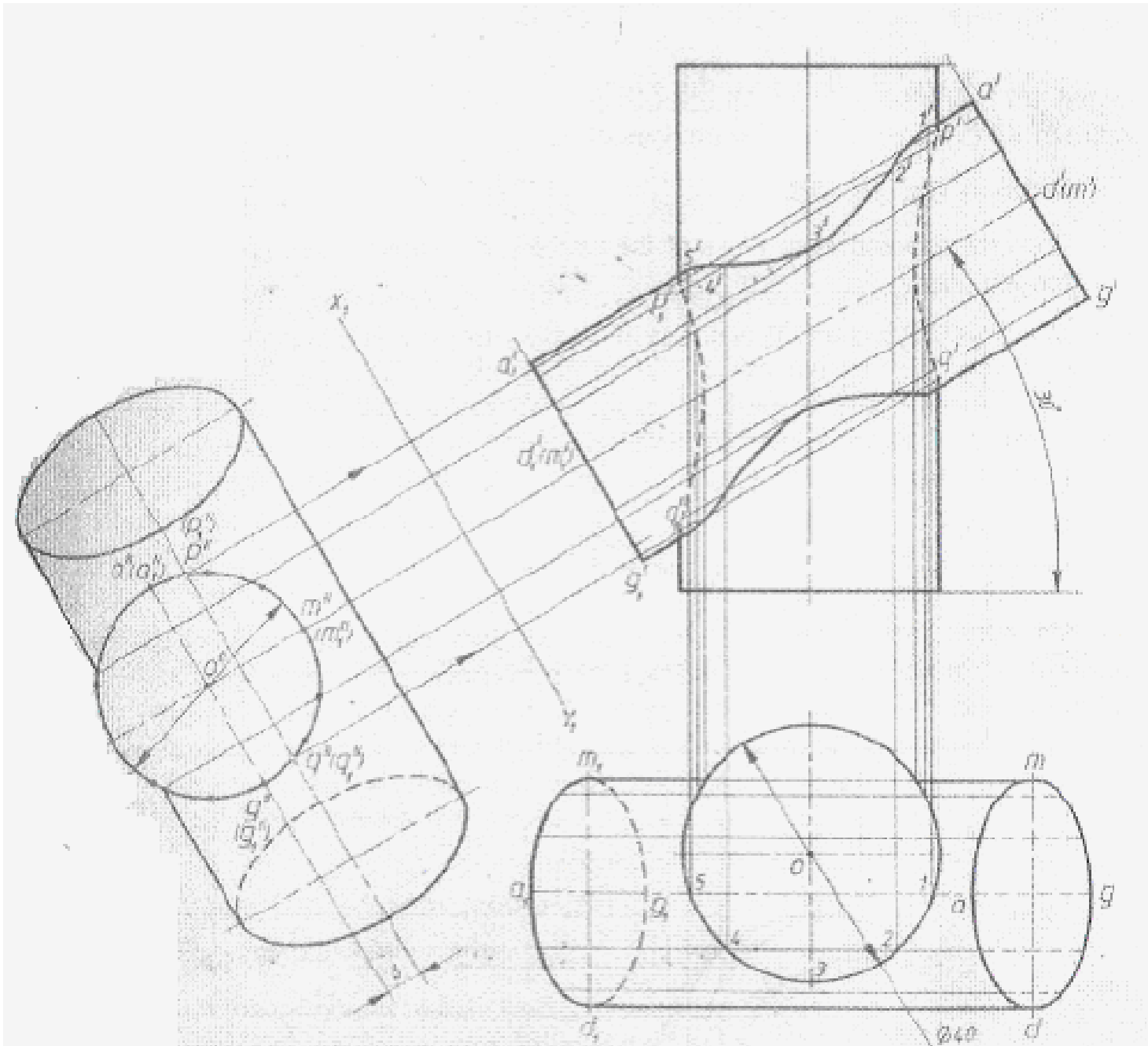

(Taken from K.R. Gopslakrishna, Engg. Drawing, subhas store book center)

INTERSECTION OF PRISM AND PYRAMID

Prob. 8) A square pyramid with a base side of 55 mm and an axis length of 80 mm stands on its base on the HP with the sides of base equally inclined to the VP. A triangular prism with a base side of 34 mm and length of axis 100 mm, penetrates the pyramid completely. The axis of the prism is perpendicular to the VP and intersects the axis of pyramid at 24 mm from the HP. One of the lateral faces of the prism is perpendicular to the HP. Draw the three views of the solids showing LOI.

(Taken from Dhananjay A Jolhe, Engg. Drawing, MGH)

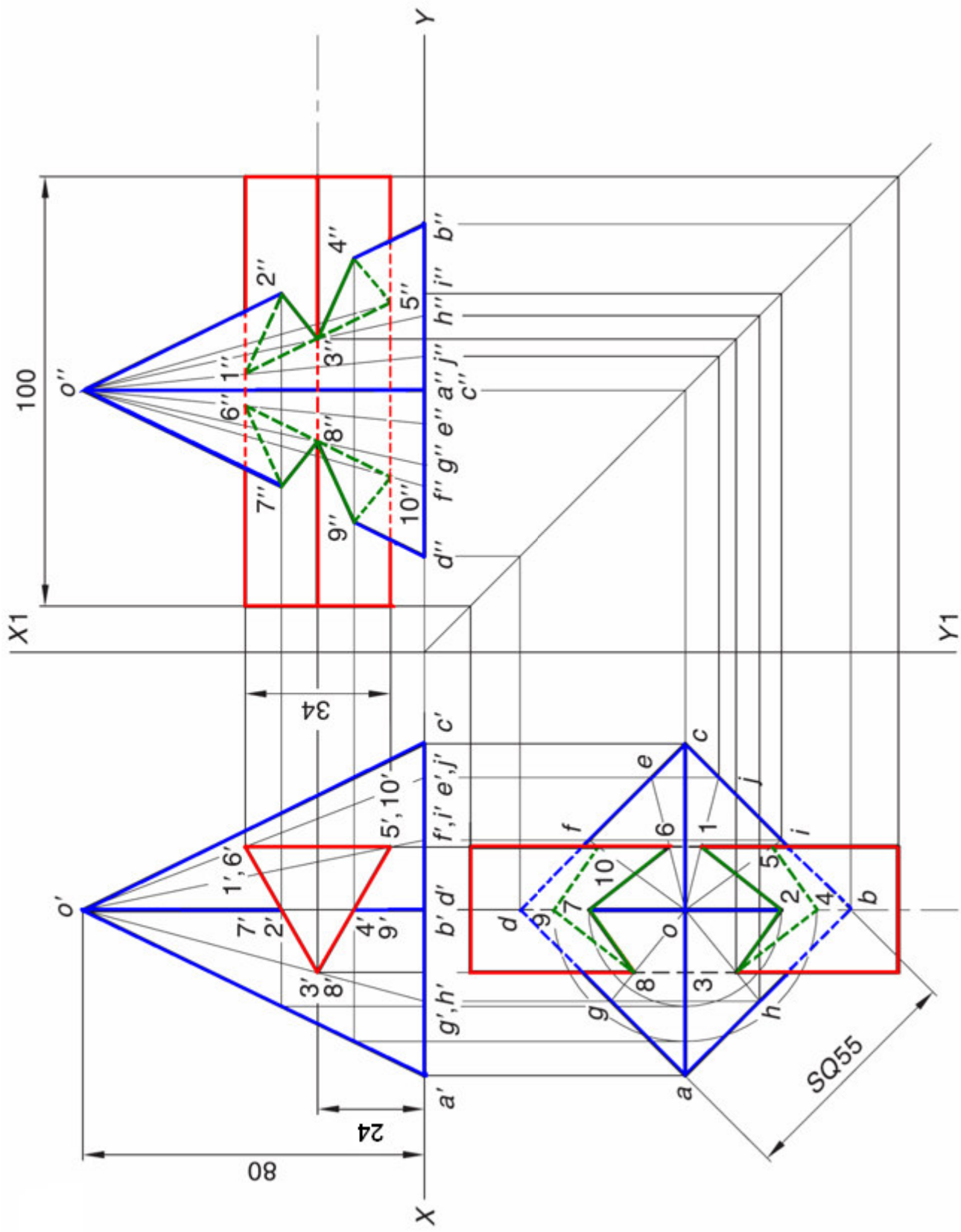

Solution is Correct ??????